

MIATATUDES

The Official Newsletter of the Sacramento Area Miata Owners Association

Volume 13

This months events

- January 8th
Monthly Meeting at
Aces
I-80 and Madison
- January 12th
Cultured Cabernets
- February 7—9th
SJVMC Coastal
Cruise X
- February 12th
NUMMI Tour
- February 12th
Monthly Meeting

Inside this issue:

Miata Margaret's Musing	2
Three Secret Miata Projects	3
Tech Tips	4
ZOOM Light	5
Events Calendar	6
More coming events	7
The Last Word	8

The New BOO — Who?

Once again SAMOA has a new Board Of Officers. The following short biographies, are designed to give all members a quick introduction to them.

President - Margaret McConnell

MARIOTA's 'birthday' (she's a '95 Montego sporting #33) was September 7, 1995—which also sort of became a birthday for me. Never in my wildest dreams did I think that a little car would make such a big change in my life. When my father told me he's seen a notice in the Bee about a Miata club, my response was: "I don't join clubs!" On the other hand, I had a whole lot of questions about my new toy, questions that my so-called dealer wasn't answering. I figured just one meeting would give me the tech info I needed, and then I'd be off doing my own thing. Uh, oh—this was a group of really, really nice people (funny, they all had these cute little cars), and they were having just way too much fun. That first weekend I went to dodge cones at this thing called an autocross, not even having figured out how to get my hardtop off yet. Next day, my parents became hardtop-sitters. First road event, I added those little air horns before even returning home—the first of a considerable number of parts and pieces. A couple of months later, ohmygoodness, I couldn't believe I was doing the Miatatudes editor thing. Seven-plus years later, after almost five years as Miatatudes editor, one year as treasurer, three years on Gold Rush Committee, countless events (even leading a bunch by myself), having to prove to my kids that yes, Mom really owns her own helmet, looking all over Scotland for Miatas (not very many), SAMOA is more like a family than just a bunch of folks who all happen to own Miatas. I am proud to be a part of this wonderful family. Now, let's go have some fun!

Vice President - Kevin Chapnick

Kevin purchased the Miata as a start to a mid-life-crisis. He then found out how much he really liked the car and what it represented. Not only was it fun but the Miata people were great too. He and his wife Barbara love to cruise to the beach or to the mountains for the day in their Miata. When it came to naming the car, they sat down with the family to make a list of possible names. The kids came up with close to 70 names, most of which included red. So they voted and came up with Pooh Bear because the girls all love Disney and especially Pooh. Kevin has added an autopower full roll bar with padding, Panasport rims and Nitto 450 tires 205/50/15's, Crazy Red Air Horn, P1aa 1200 fog lights, new top, cup holder, new windshield, door jam skid plates, and a door ding. Kevin has spent the last 18 years in the U.S. Air Force as a Flight Engineer on the KC-10 aircraft. He gets to travel to a lot of cool places all over the world. He and Barbara have 3 children, and live on Travis AFB. Kevin loves nature and grows Bonsai trees. He really enjoys the Autocrosses and likes to discover new places around Northern California. Kevin, in a previous incarnation, was Technical Guy for SAMOA and a major organizer of the Annual Picnic.

Treasurer - Gary Bechthold

The Bechtholds purchased their Miata to have fun and they named it "Flitzer" which is German for quick... They both work at HP in logistics and their hobbies are woodworking and genealogy. They enjoy all the events. Gary's background includes 20 years in the Air Force as a helicopter pilot, which gives him an advantage in navigating road runs - he is used to seeing strange ground up close. In addition, he has been treasurer in several men's organizations.

MIATATUDES

Miata Margaret's Musings

SAMOA Officers - 2003

President

Margaret McConnell
(916) 452-7659
President@samo.org

Vice-President

Kevin Chapnick
(707) 446-0882
Vp@samo.org

Secretary

Gundi Bechthold
(916) 784-3123
and
Margaret Counter
(916) 448-5955
Secretary@samo.org

Treasurer

Gary Bechthold
(916) 784-3123
Treasurer@samo.org

Events

Robin George
(916) 359-2627
and
Ralph Gingrich
(916) 721-4499
Events@samo.org

Technical

Ray Chermak
(530) 666-5694
Tech@samo.org

Media Director

Gene Leininger
(916) 359-5689
media@samo.org

Webmaster

Hugo Schmidt
(916) 984-1262
webmaster@samo.org

Welcome to 2003! We got past the 'New Millennium' in 2000, the 'Space Odyssey' in 2001, all the variations of '20' & '02' in 2002, so now what? How about Happy SAMOA Miata-ing in 2003! No big deal you say? Well, of course it is.

We have a new BOO (Board of Officers)—a nice blend of fresh faces and 'seasoned' BOO-ers. We have new ideas, blended with the experience of Golden Oldies ideas. Most importantly, we have a whole lots of fresh, bursting-at-the-seams, ENTHUSIASM—highly contagious, infectious MIATA ENTHUSIASM. We are planning to expose everyone to this strain of enthusiasm for the sole purpose of making sure every one catches it, becomes highly Miata enthusiastic, and spreads it to every other Miata enthusiast you meet. There is only one thing anyone can do if they become infected with Miata enthusiasm—*get out there and drive your Miata!*

Hold on, now. If you are out there enthusiastically driving your Miata all by yourself, why not consider your little adventure on the road as a pre-run for a drive with a group of your Miata friends? And since we all know that Miata folks drive well and eat well, I'm sure you stop somewhere along your drive for a bite to eat. Perhaps you even have a particular destination to go do-something-you-enjoy. See where I'm going here? You're already out there enjoying yourself—it's as simple as letting a few other folks tag along. You've already done most of the 'work' by just getting out there and having fun. When you return from your little adventure (yes, I see that irrepressible grin across your face!), just jot down a few notes, check your calendar, contact Ralph or Robin to get on the calendar, and copycat your little adventure to include some of your Miata friends. See how easy it is? Now you're part of the grand plan to spread MIATA

ENTHUSIASM all around, and pretty soon you'll be telling everyone just how easy it was to have even more fun with all those tag-along friends.

Still not quite sure how to do it? Don't worry, remember those seasoned Miata folks out there? If you need any questions answered, we will help you with the answers—enthusiastically. After all, you're just one of the family—this family of Miata enthusiasts. If a whole bunch of these family members all plan these little tag-along adventures, pretty soon there will be a whole lot of activity going on and there will be so much enthusiasm out there that no one will want to miss out on any of the fun.

Oh, by the way... Why not start by joining us at the next monthly meeting at our new location. The folks at Aces at the Holiday Inn (Hwy 80 at the Madison Ave exit) seem to have caught some of our Miata enthusiasm and are doing a great job trying to please us.

Got e-mail? Haven't heard from us? Make sure we have your latest email address(es) so you won't miss out on any of the fun. Want to meet some folks from another Miata club? Join us in February as we go off for a weekend with those enthusiastic SJVMCers on their annual Coastal Cruise. Let's see if we can be even more enthusiastic than they are by having more SAMOAns there than SJVMCers. Worried about the weather? Hey, by the time February rolls around we're used to the rain and have decided that it will in no way dampen our enthusiasm.

Now, you've got the picture! Let's all get our MIATA ENTHUSIASM on the road and share some our driving adventures with as many folks as we can.

Here's wavin' at ya on the road...

Three Secret Miata Projects, by Adi Damania

MPS – these letters are whispered guardedly in the corridors of Mazda’s factory at Hiroshima. They stand for Mazda Performance Series (which supercedes the “MazdaSpeed” nomenclature). We know of at least three of these “hot” Miatas in existence. Two of these are painted bright yellow. One of these is the coupé with a rear wing spoiler, and the other is a roadster with projector lamps in the front and a mean grill. Even the instrument gauges are yellow, and labeled MPS. The engine in these two cars is the most interesting part! It is a 1.9 liter racing in-line four with at least 180 bhp taking both cars from 0-60 mph in less than 7.0 seconds. The engines in both cars are mated to the super smooth 6-speed manual transmission which seems to be the standard equipment on these cars.

The engine starts with a raspy zing. However, the real power only comes after 5000 rpm is reached. The cars handle better due to stiffer coil springs and shocks and fatter anti-roll bars on both front and rear. The rear tires are now 215/40-17 low profile versions. The most noticeable change is the new differential. Gone is the stock Torsen unit; in its place is a new prototype MPS diff that significantly changes the cornering character of the cars. For instance, the rear is not as eager to slide out on corners. This permits an enthusiastic Miata driver from going through the S-curves (like the ones on Hwy 128) without lifting his/her foot from the throttle.

The third “new” MPS Miata is the one that will get you all drooling faster than the time needed to say “Ft. Bragg”. It is the one of the “monster” Miatas with a Ford V-6 engine squeezed into the small engine bay. The hood had to be raised, with the ‘hump’ being disguised as a cowling for air intake. The fuel-injected V-6 produces 210 bhp, which is quite an improvement on the yellow MPS Miatas from Hiroshima. The engine starts immediately and then settles down to a smooth burbling idle. But shift the gear-box into first, drop the clutch, and watch the smoke from the huge 215/40ZR-17 tires in the rear-view mir-

ror as the car hurls itself forward. The 6-speed Mazda gearbox had to be replaced with a 5-speed one from a Mazda RX-7, which is still sold in Japan. This was done as the Miata 6-speed was not built to handle the torque generated by the Detroit V-6. The 0-60 time comes down further to just 5.8 seconds! This marriage of a Miata and a RX-7 with the Detroit V-6 acting as a matchmaker should give us, the best of all three worlds!!! However, now get this, the Japanese are a not too keen to have the “American” engine in one of their most successful sports cars. Hence, wild rumors are circulating that this final version of the Miata evolution will end up with a rotary engine not unlike the one in the new Mazda RX-8! On the other hand, Mazda is under some subtle pressure from Ford to produce the V-6 version and hence gain a foot-hold in the market that is currently satisfied by the BMW M-power convertibles and the Porsche Boxsters.

Paging All Long-Distant SAMOAns...

SAMOA members are spread out over a large area and some cannot always get to monthly meetings. In an effort to make it easier for these members to be more involved, I would like to organize some social get-togethers on a periodic basis in the more remote areas of SAMO-land. This would not be a regular club meeting, but a chance for members to get together, meet new folks, show off our toys, and just relax and have fun.

What I need is *any* person from each of the general areas listed below to find a restaurant location that has easy access from the freeway and that can take a group of 10-20 people with folks arriving 6:30-7:00pm Seating all at one table is not required, but safe, off-street parking is.

Areas are:

New Castle/Auburn

Elk Grove
Placerville
Fairfield

Call Miata Margaret McConnell (916) 452-7659 or send an email to president@SAMOA.org

Roll Call

New Memberships

Lorrean Puerta
99 Silver "Silver Streak"
Gary and Barbara Tamblin
01 Green

Renewed Memberships

Mark and Joanne Anderson
Dennis Dettloff and Barbara Fenner
JoAnne and Ralph Gingrich
Dwain and Lucille Haines
Margaret McConnell
George and Janet Shaw
Linda and Greg Streeter
Dennis and Mary Swaney

Renewal Reminders

Tammy and Derek Backus
Kevin and Barbara Chapnick
Mike and Helen DeLaurentis
Grant and Therese Fraser
JR and Susie Hahn
Tom and Lois Hoeffel
Carol and Leon Horst
Alan Leach
Bonnie and Dave Lutz
Jack and Elizabeth McCarthy
Jennifer Norris
Skip Noyes
Noelle and Hugo Schmidt
Steven and Michelle Sharon
Lynn Simpkin
Evert and Gus Young

Remember to get your renewal in by the 15th of the month in order to be assured of receiving your next newsletter. We don't want you to miss out on any of the fun.

Membership Card Benefits

We wish to thank the following businesses offering discounts to SAMOA members with presentation of their membership cards.

America's Tire Company
Mike Wilson (916) 331-3670
Ramps@dgweb.com

Automotive Unlimited
Personalized service after hours and weekends. 15% off Mazda parts
Darrell (916) 989-3325

AutoZone
19th & Broadway location Only
Ask for Glen
Present SAMOA card for 10% off
(916) 443-5479

Bob's Custom Upholstery
Roseville (916) 784-1442

Carquest Auto Parts
1945 Broadway location Only
Harold Taylor, Manager
Present SAMOA card for 10% off
(916) 737-7280

Check Point Motors
Dave Meyers (916) 852-0306

Chevron Lead Hill
Near Roseville Auto Mall
\$10 off smog check
Dan Drifhill (916) 786-9888

Clearwater Audio
Clearwater Speakers
Club Discounts
Skip Noyes (916) 362-5871
www.clearwateraudio.com

The Crazy Red Italian
Miata parts, accessories, service
Dave DeNuzzo (916) 456-2277
www.crazyred.com

Discount Tire Centers
Citrus Heights (916) 725-7337

Great Valley Mazda
Sacramento (916) 973-3240

Harbor Freight Tools
6964 65th Street, Sacramento
Dan Rasmussen (916) 393-7875

Kneisels Body Shop
Dave or Robert (916) 969-0788

Made in Japan / Made in America
10% off parts/labor, repair or service
Rancho Cordova (916) 635-7444
Roseville (916) 773-0769
Sacramento (916) 349-8919
Sacramento (916) 486-4100

Mazdas Plus
Harold Brown (916) 421-5708

Movado Body Shop, Inc.
(916) 482-7818

OK Tires of Sacramento
(916) 331-2751

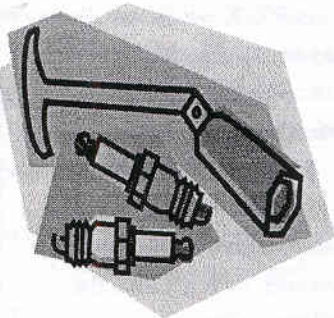
Tech Tips, by Ray Chermak

Here's a little New Year quiz... true or false:

1. When defrosting the windows, it's a good idea to turn on the air conditioner.
2. It is important to change the air in your tires at least twice per year.
3. Changing brake and clutch fluid should be done every 30,000 miles.

Answers:

1. True. You don't have to freeze in the process, either. Go ahead and crank the heat up. Make sure that the air source is set for fresh air and is not recycling the air already in the car. The air conditioner removes some of the moisture in the air and the dryer air works better for defrosting. A side benefit is that the air conditioning system is exercised and properly lubricated (the lube is in the coolant). If you don't use air for defrosting or you're lucky and never have to run the defroster, the air conditioner should be run for a few minutes every week anyway.
2. False. But since we're on the subject, let's review tire pressures. For most people, the factory recommended pressures are fine. They will provide the best compromise between handling and ride quality. Increasing the tire's pressure may make the car feel more 'sporty' but probably won't give a real advantage in traction. In fact, going too far will change the shape of the tire's contact

patch and reduce traction. Experiment with pressures until you like what you feel, but start with the factory specs and don't add too much pressure at a time. Factory pressures are printed on a door sticker and are 28 pounds for most Miatae.

3. True. Some people (myself included) change every 15,000 miles. Brake fluid absorbs moisture right out of the air and several things happen when a lot of moisture is absorbed. First, the moisture in the fluid can cause deterioration of the brake system parts. Second, the fluid becomes more compressible resulting in a slightly vague feel to the pedal. Third, the fluid's boiling temperature is reduced by up to 300 degrees. If you're in the mountains or at the track and use repeated hard brake applications, the fluid could boil. If that happens, the brakes go away and don't come back until things have cooled off. Check the color of your fluid the next time you have the hood open. Most DOT brake fluids are clear or golden colored when new. If yours is really dark you probably need to change it.

Disclaimer: The vendors who appear in Miatatudes provide discounts to members when a membership card is presented. The discounts vary, but are offered. SAMOA appreciates this gesture and encourages all members to patronize these vendors. The fact that the vendor appears in Miatatudes does not constitute a SAMOA endorsement, nor does it speak of the quality of service or materials you may receive. As in buying any product or service it is important to be diligent when comparing price and determining whether you believe a vendor product meets your expectations.

MIATATUDES

Membership Card Benefits

We wish to thank the following businesses offering discounts to SAMOA members with presentation of their membership cards.

America's Tire Company
Mike Wilson (916) 331-3670
Ramps@dgweb.com

Automotive Unlimited
Personalized service after hours and weekends. 15% off Mazda parts
Darrell (916) 989-3325

AutoZone
19th & Broadway location Only
Ask for Glen
Present SAMOA card for 10% off
(916) 443-5479

Bob's Custom Upholstery
Roseville (916) 784-1442

Carquest Auto Parts
1945 Broadway location Only
Harold Taylor, Manager
Present SAMOA card for 10% off
(916) 737-7280

Check Point Motors
Dave Meyers (916) 852-0306

Chevron Lead Hill
Near Roseville Auto Mall
\$10 off smog check
Dan Driffill (916) 786-9888

Clearwater Audio
Clearwater Speakers
Club Discounts
Skip Noyes (916) 362-5871
www.clearwateraudio.com

The Crazy Red Italian
Miata parts, accessories, service
Dave DeNuzzo (916) 456-2277
www.crazyred.com

Discount Tire Centers
Citrus Heights (916) 725-7337

Great Valley Mazda
Sacramento (916) 973-3240

Harbor Freight Tools
6964 65th Street, Sacramento
Dan Rasmussen (916) 393-7875

Kneisels Body Shop
Dave or Robert (916) 969-0788

Made in Japan / Made in America
10% off parts/labor, repair or service
Rancho Cordova (916) 635-7444
Roseville (916) 773-0769
Sacramento (916) 349-8919
Sacramento (916) 486-4100

Mazdas Plus
Harold Brown (916) 421-5708

Movado Body Shop, Inc.
(916) 482-7818

OK Tires of Sacramento
(916) 331-2751

Tech Tips, by Ray Chermak

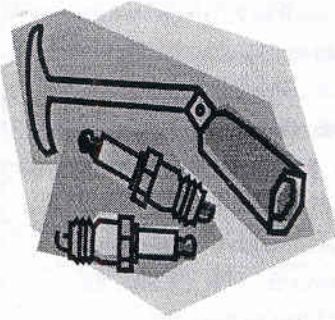

Here's a little
New Year
quiz... true or
false:

1. When defrosting the windows, it's a good idea to turn on the air conditioner.
2. It is important to change the air in your tires at least twice per year.
3. Changing brake and clutch fluid should be done every 30,000 miles.

Answers:

1. True. You don't have to freeze in the process, either. Go ahead and crank the heat up. Make sure that the air source is set for fresh air and is not recycling the air already in the car. The air conditioner removes some of the moisture in the air and the dryer air works better for defrosting. A side benefit is that the air conditioning system is exercised and properly lubricated (the lube is in the coolant). If you don't use air for defrosting or you're lucky and never have to run the defroster, the air conditioner should be run for a few minutes every week anyway.
2. False. But since we're on the subject, let's review tire pressures. For most people, the factory recommended pressures are fine. They will provide the best compromise between handling and ride quality. Increasing the tire's pressure may make the car feel more 'sporty' but probably won't give a real advantage in traction. In fact, going too far will change the shape of the tire's contact

patch and reduce traction. Experiment with pressures until you like what you feel, but start with the factory specs and don't add too much pressure at a time. Factory pressures are printed on a door sticker and are 28 pounds for most Miatae.

3. True. Some people (myself included) change every 15,000 miles. Brake fluid absorbs moisture right out of the air and several things happen when a lot of moisture is absorbed. First, the moisture in the fluid can cause deterioration of the brake system parts. Second, the fluid becomes more compressible resulting in a slightly vague feel to the pedal. Third, the fluid's boiling temperature is reduced by up to 300 degrees. If you're in the mountains or at the track and use repeated hard brake applications, the fluid could boil. If that happens, the brakes go away and don't come back until things have cooled off. Check the color of your fluid the next time you have the hood open. Most DOT brake fluids are clear or golden colored when new. If yours is really dark you probably need to change it.

Disclaimer: The vendors who appear in Miatatudes provide discounts to members when a membership card is presented. The discounts vary, but are offered. SAMOA appreciates this gesture and encourages all members to patronize these vendors. The fact that the vendor appears in Miatatudes does not constitute a SAMOA endorsement, nor does it speak of the quality of service or materials you may receive. As in buying any product or service it is important to be diligent when comparing price and determining whether you believe a vendor product meets your expectations.

2003 SAMOA Master Events Calendar

Event Categories

M - Mild, relaxed, scenic, slower paced, passenger friendly driving. Main objective: enjoy the scenery, eat and socialize.

I - Interesting, intentionally twisty roads for driver enjoyment. Allows passenger to take in scenery. Main objective: quick paced run usually ending with food and socializing.

A - A blend allowing driver to exercise his/her skills on traditional Miata roads. Main objective: more intense run ending with refreshment and road stories.

T - A brisk trip or overnighter possibly involving freeways and highways. Main objective: travel some distance to meet, eat and socialize.

A - Adventuresome outing with emphasis on back roads with lots of curves and hills. Possibly passenger unfriendly. Includes track events. Main object: ZOOM, ZOOM!

For event planning, assistance, and scheduling information contact one of the event chairmen, Robin George or Ralph Gingrich either by phone, or email to events@samo.org

January

Contact

1	New Year's Hangover Cure - Free	Ron Petrich (916) 454-1008	A
8	Meeting - Aces		
12	Cultured Cabernets - \$	Margaret McConnell (916) 452-7659	M

February

7 - 9	SJVMC Costal Cruise X - \$\$\$-H	Margaret McConnell (916) 452-7659	I
12	Nummi Tour	Genny & Bob Paauwe (916) 672-0601	M
12	Meeting - Aces		

Long Range Planning

24-Apr	Miatas at Thunderhill III	Bonni Weatherwax	A
6-May	Miatas in Moab		
21-Jun	Hisorical Hide and Seek	Genny & Bob Paauwe (916) 672-0601	M
Aug 15-17	Monterey Automotive Weekend		
16-Aug	Hot August Nights Ice Cream Run		
Oct 10-12	Columbus Day Getaway		

Key: \$ = under \$30 \$\$ = under \$75 \$\$\$ = over \$75 H - hotel reservation required

Coming Attractions

Jan 12th Cultured Cabernets. Full as of press time, but contact Margaret McConnell for further info.

Feb 7—9 SJVMC Coastal Cruise X

...or: I've-recovered-from-the-holidays-and-now-I'm-winter-stir-crazy... In years past, SAMOA outnumbered SJVMCers at their own event and we always had a lot of fun. They are excited to have us officially join them again. We SAMOAns will do a quick eat & drive (or drive & eat) down to Fresno Friday night so we can meet our hosts for an 8am breakfast. Then we'll drive the morning to our lunch destination at beautiful Morrow Bay for lunch, followed by the drive north to our destination at San Simeon on the ocean (Best Western).

The hotel has an indoor recreation area with swimming pool, spa, pool tables and picnic tables. Afternoon socializing in this area is common and we can bring our own munchies and beverages. Later that evening we'll all head off for more eating (we eat as well as we drive) at a dinner location tbd.

Sunday morning we will do breakfast at Ragged Point Inn, Ragged Point, followed by driving Big Sur. the last leg with SJVMC includes a stop at Nepenthe, from where we will drive north up Highway 1. For those that are interested, we will stop at Fisherman's Wharf, Monterey for lunch.

As soon as I receive the remaining information from SJVMC, I will let everyone know. In the meantime, contact Margaret McConnell at 916-452-7659 or mariota-33@attbi.com. Let's turn out in big enough numbers so we can thank SJVMCers for organizing this fun event for SAMOAns.

Late info: A block of 25 rooms has been reserved for Saturday night at the Courtesy Inn under "Miata Club". The rate is: \$49/night double occupancy. The phone number is 1-800-555-5773. Friday night TBD.

Membership Application

1) Please check your status: New member Renewing Member Information Update Only

2) Name: _____

Name of spouse: _____

3) Address: _____

4) Telephone: () _____ E-Mail: _____

5) Your Miata: Year _____ Color: _____ Name: _____

Mail this form and your check for \$24 to:

SAMOA PO Box 417103 Sacramento, CA 95841-7103

Note: If you are a member in good standing, use this form to notify the club of any changes to the above information.

More Coming Attractions

Feb 12th NUMMI tour

Join us for a tour of the New United Motor Manufacturing, Inc. (NUMMI) plant in Fremont. NUMMI is a joint venture between Toyota and General Motors, manufacturing 220,000 cars and 150,000 trucks annually.

NUMMI currently manufactures the Corolla, the new Pontiac Vibe and every Toyota Tacoma pickup sold in the U.S.

The tour is limited to 48 people (all guests MUST be over the age of 10) and will go from 1 p.m. to 2:30 p.m. (NUMMI only offers tours Tuesday-Friday, so I chose a state holiday for our tour.)

Learn more about NUMMI: www.nummi.com

Meeting info: *8 a.m. sharp departure (meet at 7:45 a.m.) *Chevron Station, 1015 Jefferson Blvd (at Jackson), West Sacramento

By: Genny & Bob Paauwe E-Mail: genny@bobshome.org

Phone: (530) 672-0601

SAMOA 2003 Survey

If you weren't at the December meeting (... and why weren't you...), you will find the *SAMOA Database Updates and Survey for 2003* included in this January 2003 Miatatudes. Please take a bit of time to verify the information we have on file for you and answer a few questions that will help your new 2003 Board of Officers plan the new year. Tell us what you would like to see in your club. Yes, SAMOA is *your* club. It is what *you* help make it. If you find yourself saying: Gee, I wish someone would do _____, why not help us do it. It doesn't take much effort from a whole lot of people to make SAMOA a really great Miata Club. Gosh, isn't there a saying out there? **JUST DO IT!!!** Think we can borrow it?

To give us your thoughts and ideas, return the survey to:

2003 Survey
SAMOA President
PO Box 417103
Sacramento CA 95841-7103

Better yet, bring it with you to the January meeting, chat with your SAMOA friends and change some of your ideas into reality.

2003 SAMOA Master Events Calendar

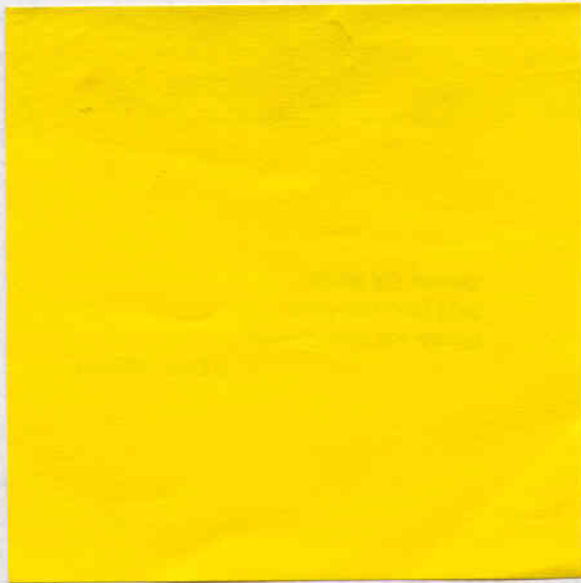

Sacramento, CA 95841-7103

P. O. Box 417103

-ESTABLISHED 1990-



The Last Word

First of all, I'd like to thank all of you for the chance to be your media director. This is your club, and my part of it is to give you a good newsletter, one that you want to sit down and read. To that end, I've made some changes to the content and format, as you have noticed in this issue. There will be more feature columns, such as the ones by Bonni Weatherwax and Ray Chermak, and less repetition of information that can be better found on the website. Since the website is updated regularly, that's the best place to check for new events, items for sale, etc. For those of you who don't browse the web, or maybe don't own a computer, I'm not planning to omit the information needed to participate in events, just downplay that coverage.

To that end, I'm looking for writers, either as regular contributors or of special interest articles. The major criteria for acceptance is that the topics should relate to the Miata and/or SAMOA. Also, I will be adding a section, 'The Readers Write', for letters to the editor (assuming there are some). This gives you the opportunity to sound off on what you want to see in the club. Send them to:

SAMOA Media, PO Box 417103, Sacramento, Ca. 95841-7103; or via email to media@samoa.org.

For those of you who contributed articles and photos for this issue, I want to let you know how much I appreciate receiving them, and apologize for not having enough room to include them all.

I thank you again for the chance to work for SAMOA, and I look forward to your comments and articles.

Gene Leininger

Editor's postscript. There are some people who aren't happy unless they can find fault. Since I want everyone to be happy, I've included an error in Miatatudes just for them.